

DESIGN NOTES

Chip Set Offers Low Cost Alternative to 48V Telecom Modules

Design Note 261

Kurk Mathews

The demand for high performance 48V input telecom modules has never been higher. The latest generation modules offer high current, high efficiency alternatives to traditional low voltage potted supplies. Although these drop-in solutions are attractive, their higher cost can quickly add up as product volumes increase. Replacing a module with an on-board solution based on the new LT[®]1681/LTC[®]1698 chip set significantly reduces system cost and takes full advantage of board area, minimizing the need to derate output power at elevated ambient temperatures.

The new LT1681 controller contains all the necessary functions for a synchronous forward converter and works together with the LTC1698 secondary controller for isolated applications. The LT1681 features include current-mode operation up to 250kHz, 75V high side driver, leading edge blanking, input under/over voltage protection, synchronous gate output and a thermal shutdown pin. The LTC1698 interfaces directly with the LT1681 providing an error amplifier, current limit and output over voltage protection in addition to synchronous gate drivers.

Isolated 48V to 3.3V Supply

The schematic in Figure 3 presents a complete 36V_{IN} to 72V_{IN} to 3.3V_{OUT}/20A power supply. Total component cost is typically below \$30 (50k pcs). The 2-transistor forward converter utilizes low voltage primary switches and provides for recovery of the transformer's mutual and leakage energy. The LTC1698 secondary controller synchronizes with the LT1681 via a small pulse transformer and drives secondary synchronous MOSFETs. Efficiency is shown in Figure 2. The LTC1698 includes an error amplifier and optocoupler drive buffer, eliminating the output feed-forward path and loop compensation issues associated with '431 type references. A margin pin allows the output voltage to be adjusted $\pm 5\%$. Other output voltages can be realized by substituting components into the same basic circuit. Contact the factory for more information including half-brick layout information (see Figure 1).

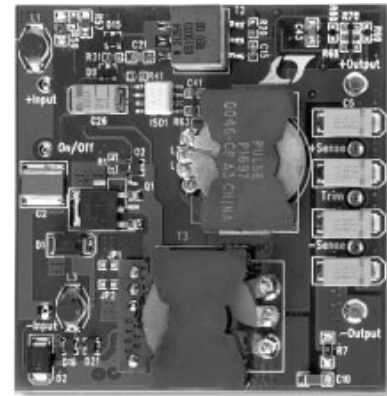

dn261f01

Figure 1. 3.3V/20A Supply in Half-Brick Footprint

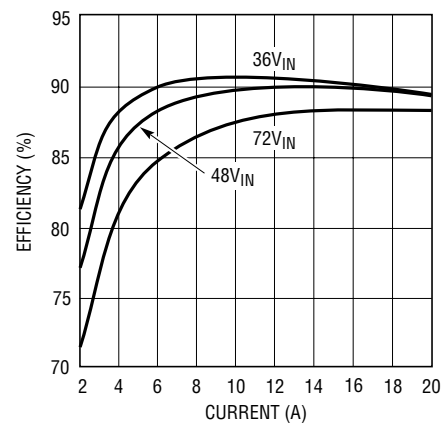

dn261f02

Figure 2. 3.3V Efficiency (See Figure 3)

Conclusion

The LT1681/LTC1698 combine to provide a low cost, discrete alternative to telecom modules. The LT1681/LTC1698 features reduce circuit complexity. High efficiency synchronous operation combined with the thermal advantages of an on board supply make the LT1681/LTC1698 the ideal choice for high current, low cost isolated converters.

LT, LTC and LT are registered trademarks of Linear Technology Corporation.

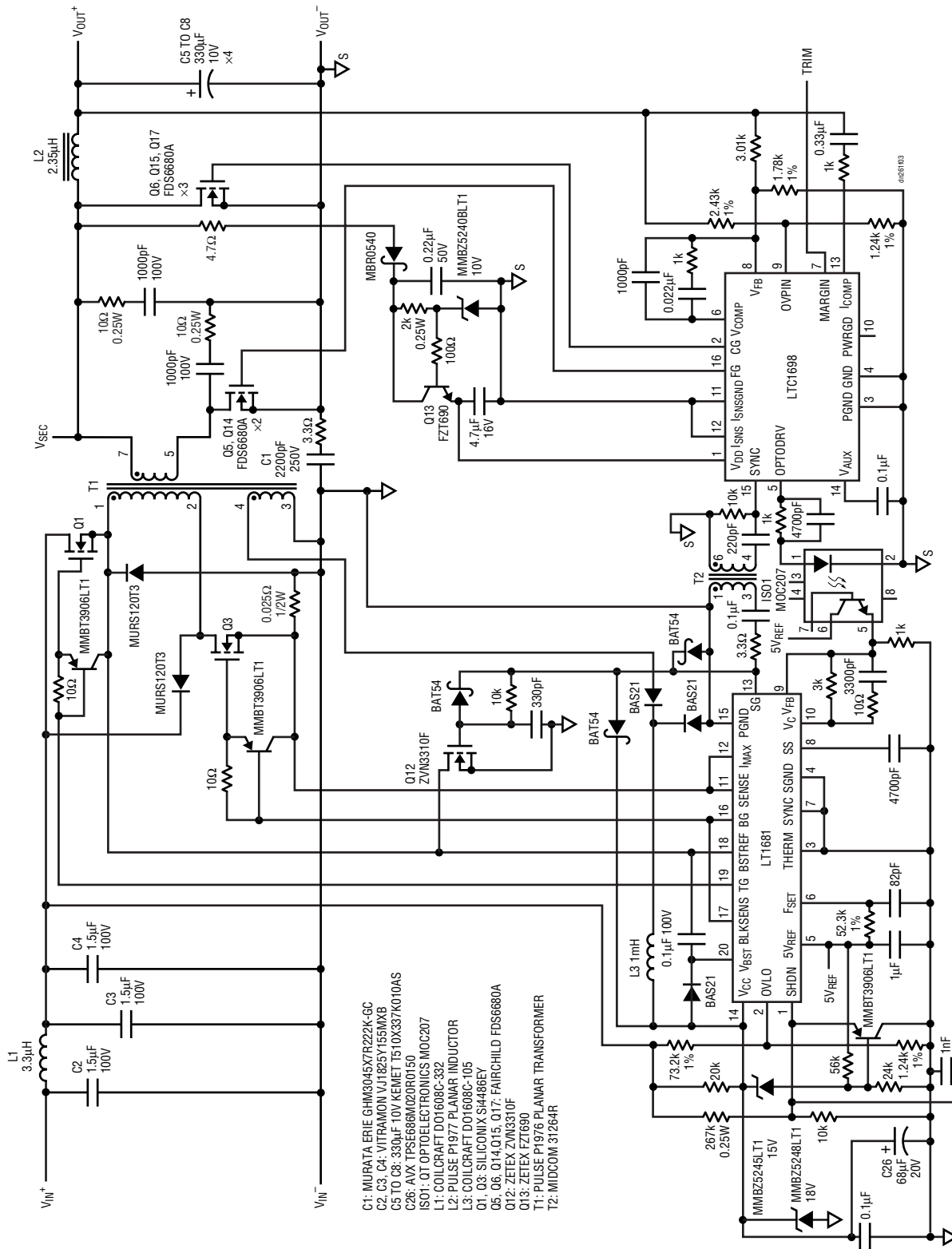

Figure 3. 36V-72V DC to 3.3V/20A Isolated Synchronous Forward Converter

Data Sheet Download

<http://www.linear-tech.com/go/dnLTC1698>
<http://www.linear-tech.com/go/dnLT1681>

For literature on our Controllers, call **1-800-4-LINEAR**. For applications help, call (408) 432-1900, Ext. 2593